

## Drop-In Drop-in refrigerated well, static (1 GN container capacity)

ITEM # \_\_\_\_\_

MODEL # \_\_\_\_\_

NAME # \_\_\_\_\_

SIS # \_\_\_\_\_

AIA # \_\_\_\_\_



341156 (D10C1)

Drop-in Refrigerated Well,  
static (1 GN container  
capacity)

### Main Features

- CB and CE certified by a third party notified body.
- Designed to be positioned in flush installation providing improved cleanability and suitable for modern design installations.
- Designed to serve the food in gastronorm containers.
- Suitable for GN 1/1 containers with a maximum height of 200 mm.
- Precise temperature control and setting at 0,1°C .
- As standard the product comes with digitally controlled thermostat which is in line of HACCP norms and provides visual alarm as a warning of the increasing or decreasing temperatures.
- Available drop-in dimensions: 1, 2, 3, 4, 5, 6 GN.
- Food introduced at the correct temperature maintains its core temperature according to Afnor Standards.
- Automatic defrosting guarantees evaporators clearance and efficient well cooling.
- Remote version is available.

### Construction

- Well bottom is inclined to facilitate water drainage.
- Well in 304 AISI stainless steel with rounded corners to facilitate cleaning operations. The well is also equipped with a drain hole.
- Electronic control with temperature display.
- IPx2 water protection.
- The bottom is equipped with copper tubes to ensure proper cooling, with this system the air touches the cold surface and gets cooled.

### Sustainability

- Hydrocarbon refrigerant gas R290 for the lowest environmental impact (GWP=3) - CFC and HCFC free.
- High-density expanded polyurethane foam with cyclopentane guarantees excellent well insulation to reduce energy dispersion.

APPROVAL: \_\_\_\_\_

**Rear side**

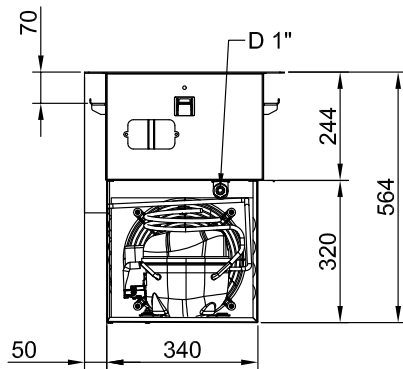

**Side**

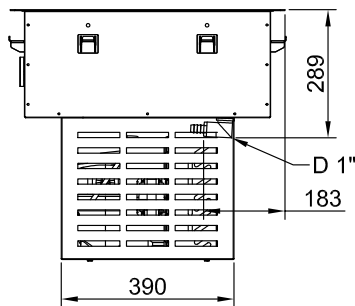

D = Drain  
EI = Electrical inlet (power)

**Top**

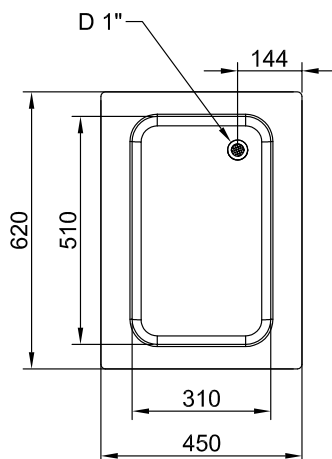

**Electric**

Supply voltage:  
341156 (D10C1) 220-240 V/1N ph/50 Hz  
Electrical power max.: 0.47 kW

**Water:**

Water drain outlet size: 1"

**Key Information:**

External dimensions, Width: 450 mm  
External dimensions, Depth: 620 mm  
External dimensions, Height: 595 mm  
Net weight: 41.5 kg  
Shipping weight: 51 kg  
Shipping height: 720 mm  
Shipping width: 490 mm  
Shipping depth: 660 mm  
Shipping volume: 0.23 m<sup>3</sup>  
Set temperature: -15 / 0 °C

**Sustainability**

Noise level: 62 dBA

# Drop-In refrigerated well, static (1 GN container capacity)



CAPACITY	CUTOUT		LOWERING FOR FLUSH INSTALLATION		C	K
	A1	B1	A2	B2		
1GN	380	580	454	624	560	380
2GN	700		774		880	
3GN	1030		1104		1200	
4GN	1350		1424		1530	
5GN	1670		1744		1850	
6GN	2000		2074		2180	

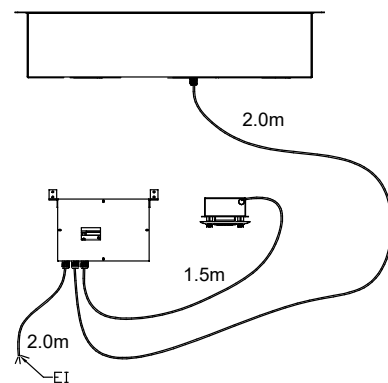
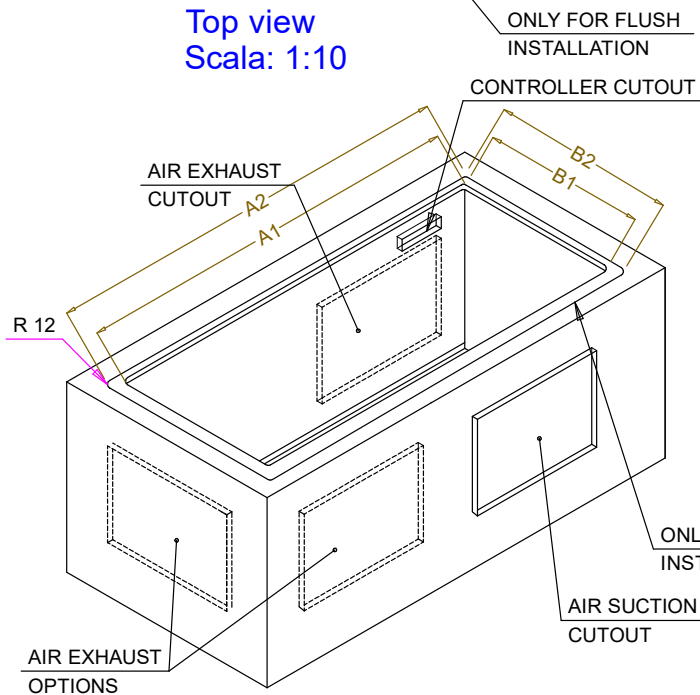

595T01S00 - COLD STATIC WELL

Drop In

Drop-in refrigerated well, static (1 GN container capacity)

The company reserves the right to make modifications to the products without prior notice. All information correct at time of printing.